



S2B-S3B

POWER, SIMPLIFIED



INDUSTRIAL
VACUUM SOLUTIONS

 **Nilfisk**

S2B AND S3B: SINGLEPHASE WET AND DRY INDUSTRIAL VACUUMS, MUCH MORE THAN ESSENTIAL



Essential, powerful, efficient.

Models S2B and S3B are the starting point to get the maximum advantages and the undisputed benefits that include, among others, the obvious and immediate savings of time and resources.

2 single-phase models (2 or 3 kW), respectively with two or three independent motors, the S2B and S3B industrial vacuums can collect solids and liquids. In particular they are designed to be used in mechanical manufacturing production sites to extract metal chips, metal filings, oil and lubricant solutions.

S2B and S3B, much more than essential.



TECHNICAL DATA

Description	Unit	S2B	S3B
Voltage	V	230	230
Frequency	Hz	50-60	50-60
Protection class	IP	43	43
Insulation class	Class	I	I
Rated power	kW	2	3
Airflow without hose	L/min	5.500	8.100
Vacuum max	kPa	21	21
Sound pressure level	dB(A)	74	75
Container capacity	L	50	50-100
Main filter area	cm ²	19.500	19.500
Inlet	mm	70	70
Length x Width x Height	cm	79,5x60x127,5	79,5x60x127,5-157
Weight	kg	64	67-70



Optional accessory and hose holder.



Optional HEPA filter

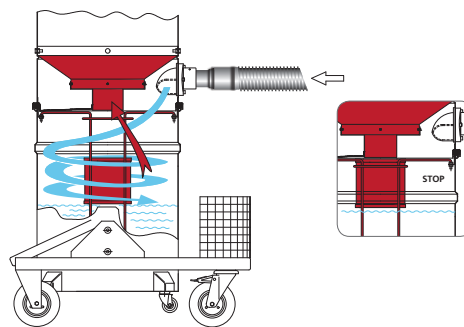

Optional mechanical floater for liquid.

INDUSTRIAL
VACUUM SOLUTIONS

Nilfisk AB
Tel: 031 706 73 00
www.industrial-vacuum.nilfisk.se

